



---

OPERATING INSTRUCTIONS  
FOR MULTIMOR Mk. 4

**CONTENTS**

English	..	..	..	..	5
Française	..	..	..	..	8
Deutsch	..	..	..	..	11
Svenska	..	..	..	..	14
Español	..	..	..	..	17

---

## OPERATING INSTRUCTIONS FOR MULTIMINOR Mk. 4

**General:** The instrument is supplied in an attractive plastic case with leads, prods and clips.

**Preliminary Check.** To ensure accurate readings, the instrument must be used face upward. If the pointer does not read zero, the slotted mechanical zero adjuster which is located below the scale should be readjusted.

**The Scale Plate.** Two basic scales are provided, each approximately 2.75 inches (6.98 cm.) in length. The inner scale is for resistance measurements only and is scaled 0-20k  $\Omega$  (125  $\Omega$  mid-scale). The outer scale is for a.c. and d.c. voltage and d.c. current; it has 50 divisions which are calibrated 0-25 and 0-100.

---

## USING THE INSTRUMENT

**A.C. and D.C. Voltage Measurements.** To measure a.c. or d.c. voltage the leads should be connected across the source to be measured, the basic scale should be used (i.e. 0-25 or 0-100). The readings obtained should be multiplied by the appropriate factor, e.g., assuming that a 250V mains supply is being measured, the range switch should be set to 250V a.c. The readings should then be made on the scale marked 0-25 and multiplied by ten.

**D.C. Current Measurements.** To measure d.c. current the meter must be connected in series with the circuit under test. Measurements are made in a similar manner to that previously described, except that the scale marked 0-100 is used throughout. The readings obtained, however, should be divided by the appropriate factor.

**Note.** If the voltage or current to be measured is unknown, always switch to the highest range, then switch progressively to a lower range until a suitable pointer deflection is obtained.

**Warning.** It is dangerous to make connections to equipment with the power on. Make a habit of connecting the instrument before switching on.

**Resistance and Continuity Measurements.** Select the resistance range required, join the leads together, and adjust the ohms zero control until full scale deflection is obtained (the ohms zero control is situated above the range switch). On switching to the other ohms range, again check the zero and adjust if necessary.

If it is not possible to set the pointer to read zero, it is most likely due to the internal cell (Ever Ready type D14  $\frac{9}{16}$  in. dia.  $\times$  2 in. long; 1.43 cm.  $\times$  5.08 cm.) being discharged. This should be checked and, if necessary, replaced. If the instrument is to be stored for any length of time, it is advisable to remove the cell.

To measure resistance, connect the leads across the component under test; if the "ohms  $\times$  1" range is used, a direct reading is given on the scale marked 0-20k  $\Omega$ . When using "ohms  $\times$  100" range, use the same scale and multiply readings by 100.

**Note.** When switched to resistance ranges, a positive potential appears at the negative socket; this is of particular importance when testing metal rectifiers, electrolytic capacitors and other polarity-conscious components.

**External Accessories.** Four external accessories are available for this instrument. These are: (a) a multiplier for the measurement of voltages up to 2500V d.c., and (b) shunts for the measurement of 5, 10 and 25A d.c.

To use the voltage multiplier, the range switch should be set to the 1000V d.c. position and the multiplier plugged in to the high potential socket on the instrument (normally this will be the + socket). The test lead is then inserted into the socket on the multiplier.

To measure d.c. current the instrument should be set to the 0.1mA range. The shunt is then plugged into the test sockets, and the test leads transferred to the shunt sockets.

**Attractive Carrying Cases.** Can be supplied in two versions: one to house the instrument,

leads, clips and prods; the other to house these and also the high voltage multiplier, a d.c. shunt and a pair of prod clips.

#### Table of Ranges

D.C. Current First indication $2\mu\text{A}$	D.C. Voltage Sensitivity (10,000 $\Omega/\text{V}$ ) First indication 2mV	A.C. Voltage Sensitivity (1,000 $\Omega/\text{V}$ ) First indication 200mV
0-0.1mA (100 $\mu\text{A}$ )	0-100mV*	
0-1mA	0- 2.5V	
0-10mA	0- 10V	0-10V
0-100mA	0- 25V	0-25V
0- 1A	0-100V	0-100V
	0-250V	0-250V
	0-1000V	0-1000V

\*Set the range switch to its .1mA (100 $\mu\text{A}$ ) position to obtain the 100mV range.

Resistance. First indication 5  $\Omega$ .  
 0-20,000  $\Omega$  125  $\Omega$  mid-scale } Using internal  
 0-2M  $\Omega$  12,500  $\Omega$  mid-scale } 1.5V cell

Accuracy. Conforms to B.S.S. 89/1954.

D.C. 2.25% of full scale

A.C. 2.75% of full scale

## COMPONENTS LIST

Cct. Ref.	Description	Remarks	Cct. Ref.	Description	Remarks	
R1	0.25 $\Omega$	Part of Shunt Board Assembly	R16	750k $\Omega$	$\pm 1\%$	
R2	2.25 $\Omega$		R17	1.5M $\Omega$	$\pm 1\%$	
R3	22.5 $\Omega$		R18	7.5M $\Omega$	$\pm 1\%$	
R4	225 $\Omega$			R19	680 $\Omega$	
R5	1450 $\Omega$			R20	33k $\Omega$	
R6	10.4 $\Omega$			RV1	800 $\Omega$	$\pm 1\%$
R7	286 $\Omega$			RV2*	100 $\Omega$ Swamp	
R8	113 $\Omega$			RV3*	500k $\Omega$	
R9	11.36k $\Omega$			MR1 } MR2 }	OA95	
R10	24k $\Omega$			M1	60 $\mu$ A, 1667 $\Omega$	Ever Ready D14
R11	9.35k $\Omega$			BY1	1.5V cell	
R12	15k $\Omega$					
R13	73k $\Omega$					
R14	1.3k $\Omega$					
R15	150k $\Omega$					

\*Pre-set for movement resistance of 1667  $\Omega \pm 0.2\%$

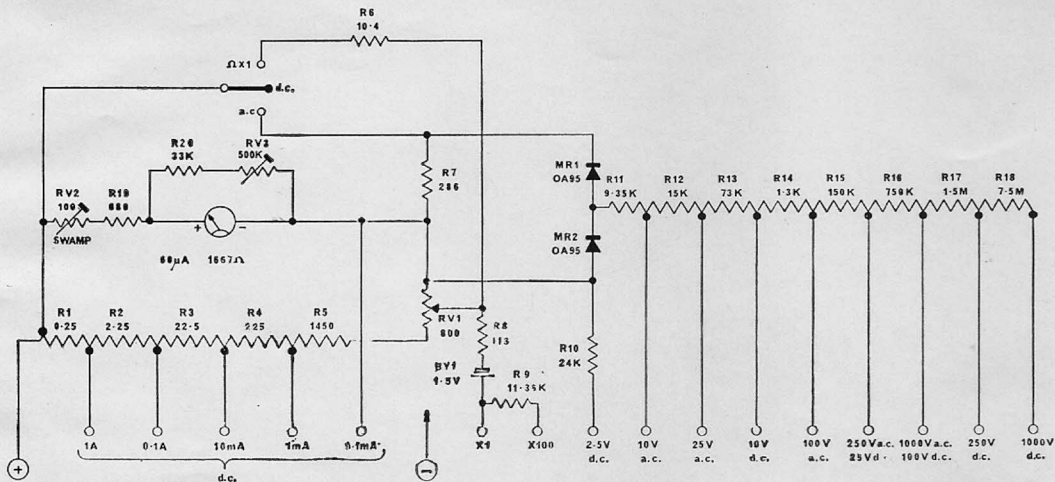

CIRCUIT DIAGRAM THE MULTIMINOR Mk. 4